

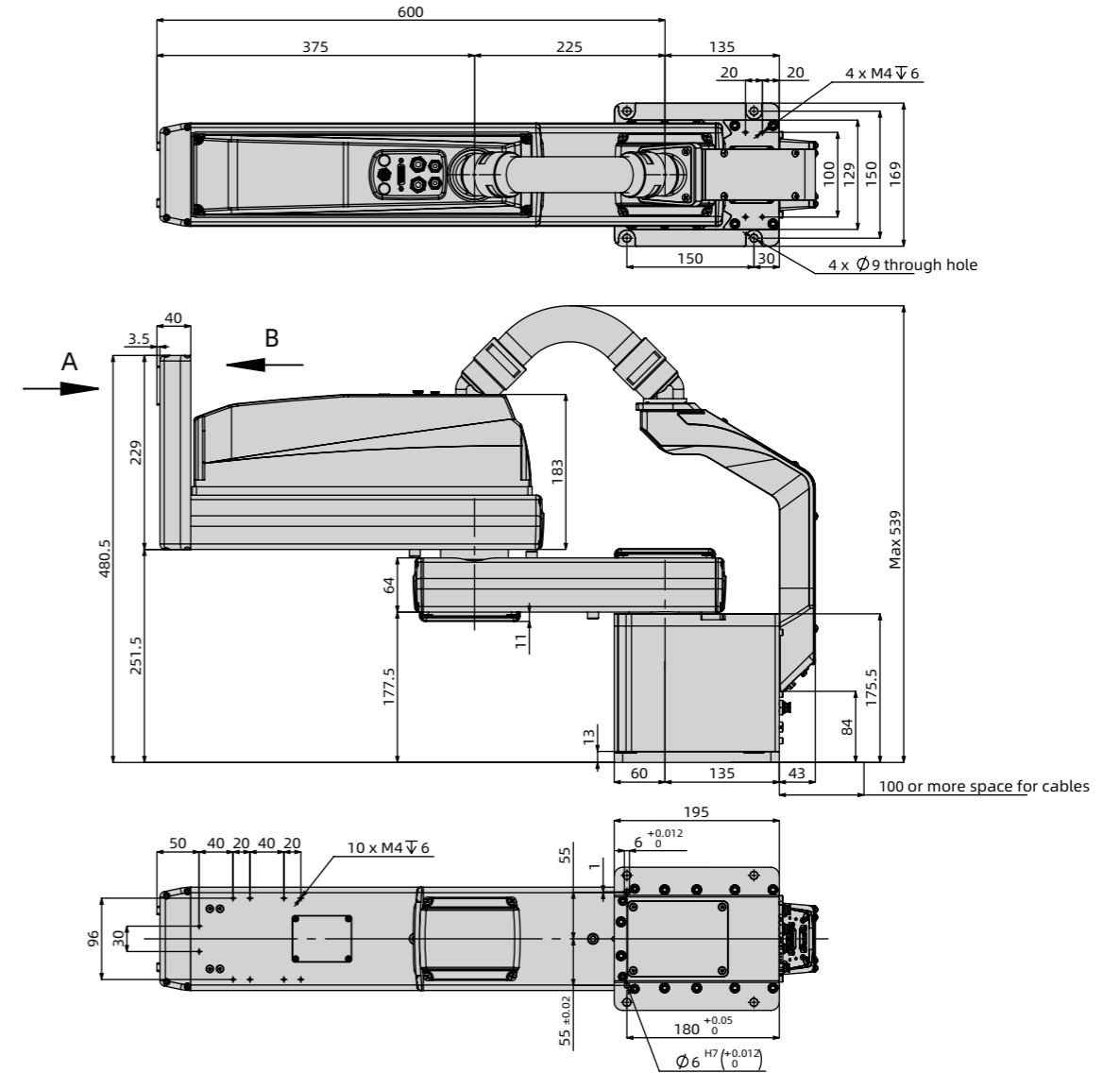

Outer Dimensions and Motion Range



Operating range

Arm length 600mm
Joint#3 stroke 100mm

Payload

Rated 5kg/Maximum 10kg

Repeatability

Joint #1,#2 ±0.025mm
Joint #3 ±0.01mm

Electrical parameters

Origin Return	None Need Origin Return
Installed wire for customer	26Pin (D-Sub Connector)
Installed pneumatic tube for customer use	φ4mm*2, φ6mm*2
Visual Interface	M12*1 Gigabit network interface
Installation Environment	Standard

※ Test results under specified conditions of our company.

Motion parameters

Joint Content	#1	#2	#3
Max Operating Speed	7398mm/s		1063mm/s
Max Motion Range	±142.2°	±148°	100mm
Motor Power Consumption	750W	750W	100W
Weight	28kg (cables not included)		

Detailed view from A

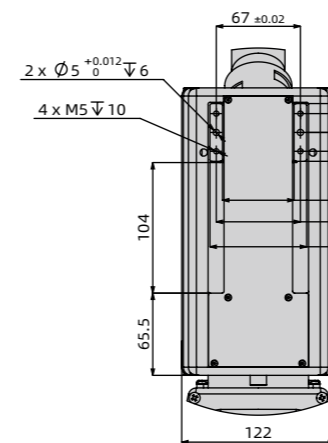

Detailed view from B

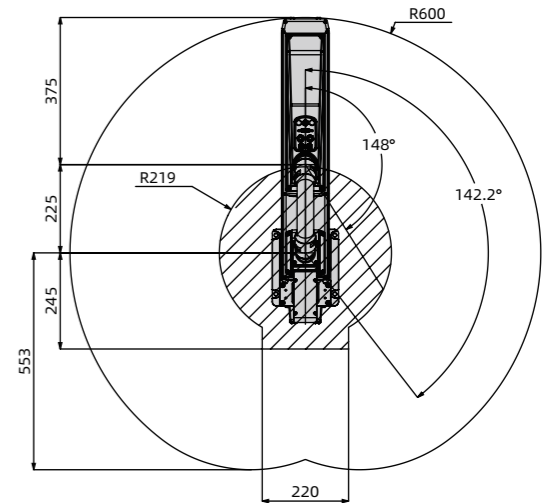
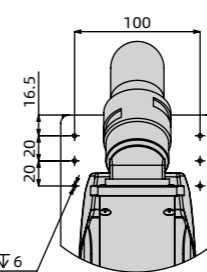

Shaded area indicates operation blind spot