



Features

- 2KHz speed loop bandwidth
- 17-bit absolute encoder
- EtherCAT bus servo support 125 μs synchronization period
- Adapt to multiple mainstream controllers
- Compact volume design meets the installation requirements of demanding spaces
- One click download and FOE function to improve production efficiency
- High quality motor bearings extend service life
- Stable operation in harsh environments

Applications

- Precision CNC Machine Tools
- Industrial Robots
- Semiconductor Manufacturing
- Intelligent Logistics Systems
- Automotive Manufacturing

Description

The MD-730N series drive, as a standard drive solution tailored for industrial fields such as 3C electronics, photovoltaic new energy, battery manufacturing, and intelligent packaging, achieves rapid and seamless integration with control systems through its embedded EtherCAT industrial bus and multi-protocol communication interfaces. By adopting new-generation power devices and innovative designs, it significantly reduces the overall space required while greatly enhancing the flexibility of drive system layouts. With superior performance and multiple advanced functionalities, it creates faster, more stable, and more precise driving scenarios, ensuring worry-free production and delivering high-efficiency productivity for your enterprise.

Drive Model Encoding

MD - 730 N S -040

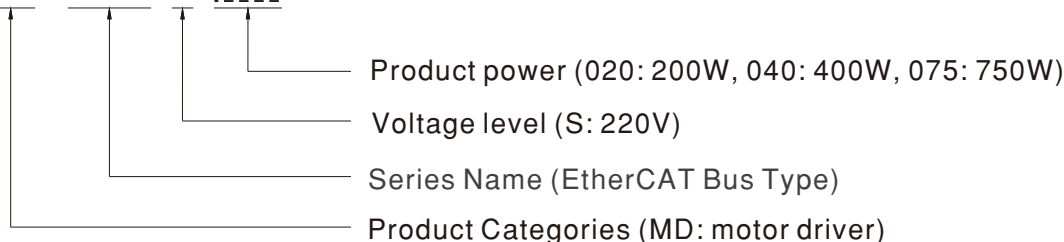



Bus-Type Servo Drive System

MD-730N series

Specification	MD-730NS-020	MD-730NS-040	MD-730NS-075
Data			
Driver power	0.2KW	0.4KW	0.75KW
OUTPUT	Continuous output current	1.6A	5.5A
	Maximum output current	5.8A	16.9A
INPUT	Main circuit power supply	Single-phase 200~240VAC, $\pm 10\%$, 50/60Hz	
	Control circuit power supply	Powered up by the bus, sharing one power supply and rectification part with the main circuit	
Braking capability	External braking resistor		Built-in braking resistor
Control mode	IGBT PWM control, sine wave current drive mode		
	220 V, 380 V: Single-phase or three-phase full-bridge rectification		
Encoder feedback	17-bit multi-turn absolute encoder, which can be used as a single-turn absolute encoder in absence of the battery		
Communication Protocol	EtherCAT		
Position control			
Position reference	The network-based instruction source is Ether CAT,PROFINET		
Supporting signal allocation change	P-OT (positive limit switch), N-OT (negative limit switch), HomeSwitch (home switch) TouchProbe1 (probe 1), TouchProbe2 (probe 2)		
Supporting signal allocation change	3 Dos Load capacity: 50 mA Voltage range: 5 V to 30 V		
Speed/torque control			
Speed control range	1:6000 (The lower limit is the threshold within which the servo drive keeps running with the rated torque load.)		
Speed reference input	Source of network-type references: EtherCAT communication		
Torque reference input			
Environment			
Operating temperature	0~55°C		
Storage temperature	-40~70°C		
IP rating	IP20		
SAFETY & EMC			
SAFETY STANDARDS	IEC 61800-5-1:2007; AMD1:2016		
EMC EMISSION	Parameter	Standard	Test Level / Note
	Conducted Emissions	EN IEC61800-3	Class A
	Radiated Emissions	EN IEC61800-3	Class A
	Voltage flicker	EN 61000-3-11 IEC 61000-3-11	-----
EMC IMMUNITY	Parameter	Standard	Test Level / Note
	ESD	IEC 61800-3, 61000-6-7	Level 3, 8KV air ; Level 2; 4KV contact
	EFT	IEC 61800-3, 61000-6-7	Level 2, 1KV
	Radiated	IEC 61800-3, 61000-6-7	
	Surge	IEC 61800-3, 61000-6-7	Level ± 2 KV/Line2KV/Line ± 4 KV/Line Earth
	Conducted	IEC 61800-3, 61000-6-7	0.15 ~ 230MHz, 10V 80% AM(1KHz)
	THD	IEC 61800-3, 61000-6-7	12%
	Individual Harmonic orders	IEC 61800-3, 61000-6-7	Class 3
	Voltage Dips and Interruptions	IEC 61800-3, 61000-6-7	Class 3 0,40%,70%,80%
OTHERS			
PACKING	0.78kg		1.04kg
DIMENSION	40*161*150mm		50*161*174mm

MD-K Series Servo Motor



Motor Model Encoding

MD - K S 2 6 S 3C;04

- Power level (01:100W,02: 200W,04:400W,08:750W)
- Rated speed (3C: 3000rpm,C:*10³)
- Brake and oil seal specification
(N: no brake and oil sealing; S: no brake, with oil seal;
C: with brake.no oil sealing; E:with brake and oil sealing)
- Shaft end specification (6: straight shaft, with keyway, threaded)
- Encoder type (2: 17 bit multi turn absolute value magnetic encoder)
- Voltage level (S:220V)
- Series Name
- Product Categories (MD: motor driver)

MD-K Motor Torque Speed Characteristics

● 100W(40 frame)

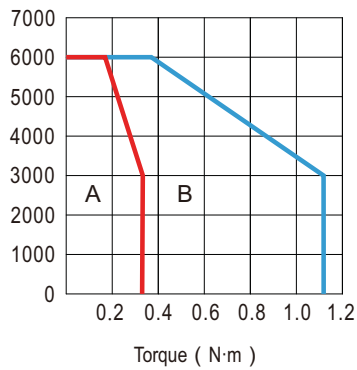

● 200W(60 frame)

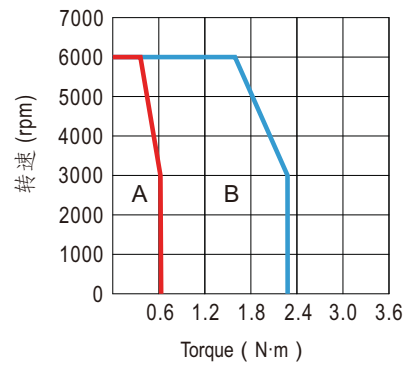

● 400W(60 frame)

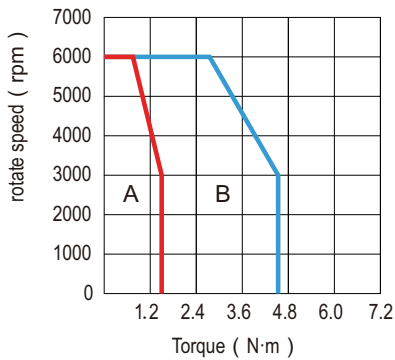

● 750W(80 frame)

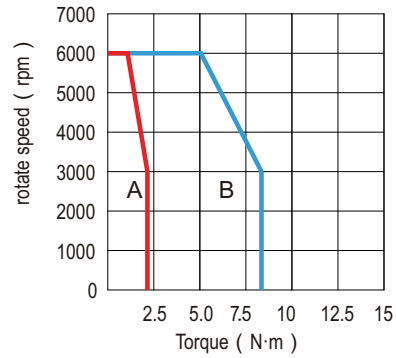

A — Continuous work area
B — Short-term work area



Specification	MD-KS26N3C01	MD-KS26C3C01	MD-KS26S3C02	MD-KS26E3C02
Technical Specifications				
Rated power (W)	100		200	
Rated current (A)	1.1		1.29	
Maximum current (A)	3.9		4.41	
Rated torque (N·m)	0.32		0.64	
Maximum torque (N·m)	1.12		2.23	
Rotor inertia (10 kg ⁴ m ²)	0.03	0.033	0.34	0.35
Overload multiplier	3.5			
Rated speed (rpm)	3000			
Maximum speed (rpm)	6000			
Flange size	40		60	
Rated voltage (V)	220			
General Specifications				
Duty	S1 (Continuous)			
Vibration class	V15			
Thermal class	Level F			
Insulation resistance	500VDC, above 10MΩ			
Excitation mode	Permanent magnetic			
Mounting mode	Flange			
Insulation voltage	1500 V AC, 1 minute (220 V level)			
Braking and maintenance	no brake and oil sealing	with brake.no oil sealing	no brake, with oil seal	with brake and oil sealing
Safety &EMC				
SAFETY STANDARDS	IEC 60034-1:2022			
EMC EMISSION	Parameter	Standard	Test Level/Note	
	Conducted Disturbance	EN IEC 61000-6-4:2019	Class A	
	Radiated Electromagnetic Disturbance	EN IEC 61000-6-4:2019	Class A	
EMC IMMUNITY	Parameter	Standard	Test Level/Note	
	ESD	EN 61000-4-2:2009	Level 3,8KV air; Level 2,4KV contact	
	RF EM-Fields	EN 61000-4-3:2006+ A1:2008+A2:2010	Level 2,10V/m	
	Fast Transients	EN 61000-4-4:2012	Level 6KV	
	Surge	EN 61000-4-5:2014	Level 2,1KV/Line to Line; Level 3,2KV/Line-Earth	
	Injected Currents	EN 61000-4-6:2014	Level 2,3Vrms/m	
Environment				
Ambient temperature	0~40°C (Non-freezing)			
Ambient humidity	20%~80% (Non-condensing)			
Storage temperature	-20~+60°C (Non-freezing)			
Storage environment	20%~80% (Non-condensing)			
Insulation resistance	500VDC, above 10MΩ			
Shock resistance	490m/s ² (5G)			
Vibration resistance	49m / s ² (10G)			



Specification	MD-KS26S3C04	MD-KS26E3C04	MD-KS26S3C08	MD-KS26E3C08
Technical Specifications				
Rated power (W)	400		750	
Rated current (A)	2.51		4.60	
Maximum current (A)	8.78		16.30	
Rated torque (N·m)	1.27		2.39	
Maximum torque (N·m)	4.45		8.36	
Rotor inertia (10 kg ⁴ m ²)	0.59	0.60	1.72	1.77
Overload multiplier	3.5			
Rated speed (rpm)	3000			
Maximum speed (rpm)	6000			
Flange size	60		80	
Rated voltage (V)	220			
General Specifications				
Duty	S1 (Continuous)			
Vibration class	V15			
Thermal class	Level F			
Insulation resistance	500VDC, above 10MΩ			
Excitation mode	Permanent magnetic			
Mounting mode	Flange			
Insulation voltage	1500 V AC, 1 minute (220 V level)			
Braking and maintenance	no brake, with oil seal	with brake and oil sealing	no brake, with oil seal	with brake and oil sealing
Safety & EMC				
SAFETY STANDARDS	IEC 60034-1:2022			
EMC EMISSION	Parameter	Standard	Test Level/Note	
	Conducted Disturbance	EN IEC 61000-6-4:2019	Class A	
	Radiated Electromagnetic Disturbance	EN IEC 61000-6-4:2019	Class A	
EMC IMMUNITY	Parameter	Standard	Test Level/Note	
	ESD	EN 61000-4-2:2009	Level 3,8KV air; Level 2,4KV contact	
	RF EM-Fields	EN 61000-4-3:2006+ A1:2008+A2:2010	Level 2,10V/m	
	Fast Transients	EN 61000-4-4:2012	Level 6KV	
	Surge	EN 61000-4-5:2014	Level 2,1KV/Line to Line; Level 3,2KV/Line-Earth	
	Injected Currents	EN 61000-4-6:2014	Level 2,3Vrms/m	
Environment				
Ambient temperature	0~40°C (Non-freezing)			
Ambient humidity	20%~80% (Non-condensing)			
Storage temperature	-20~+60°C (Non-freezing)			
Storage environment	20%~80% (Non-condensing)			
Insulation resistance	500VDC, above 10MΩ			
Shock resistance	490m/s ² (5G)			
Vibration resistance	49m / s ² (10G)			

Interface Description

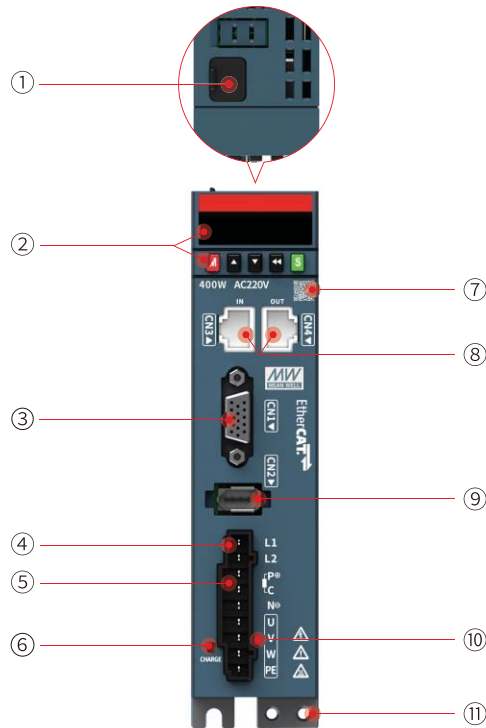

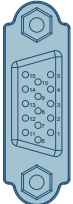

NO.	Name	NO.	Name
①	Commissioning and communication port(CN6)	⑦	QR code on machine
②	Display and operation area	⑧	EtherCAT communication network port (CN3)(CN4)
③	Control signal port(CN1)	⑨	Encoder signal port (CN2)
④	Power input	⑩	Motor power output
⑤	Braking resistor port	⑪	System ground
⑥	Charging indicator		

Terminal Definition

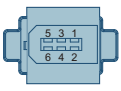

Terminal	Pin	Illustrate	
 CN1 user control terminal	10	DI1	Positive limit switch
	9	DI2	Negative limit switch
	8	DI3	Home switch
	7	DI4	Probe 2
	11	DI5	Probe 1
	15	+24V	Internal 24 V power supply, Voltage range: 20~28V, Max. output current: 150 mA
	14	COM-	(Note: A resettable fuse is shared with the CNS STO function terminals, with a total current limit of 150mA)
	13	COM+	Common terminal of DI terminals
	1	DO1+	Servo ready
	6	DO1-	
	3	DO2+	Fault
	2	DO2-	
	5	DO3+	Brake
4	DO3-		

Terminal	Pin	Illustrate	
 CN2 encoder terminal	1	+5V	5V power supply
	2	0V	-
	3	Reserved	-
	4	Reserved	-
	5	PS+	Encoder signal
	6	PS-	
	Enclosure	PE	Shield

Ether communication terminals	Pin	Illustrate		
 CN4	1	TD+	Data transmit +	
	2	TD-	Data transmit -	
	3	RD+	Data receive +	
	4/5	-	-	
	6	RD-	Data receive -	
	7/8	-	-	
	 CN3	9	TD+	Data transmit +
		10	TD-	Data transmit -
11		RD+	Data receive +	
12/13		-	-	
14		RD-	Data receive -	
15/16		-	-	

Terminal	Pin	Illustrate
 CN6 commissioning and communication	Type-C	Use a USB cable or serial cable (two sections of wiring: Type-C to serial, serial to US8) to connect the drive to the PC

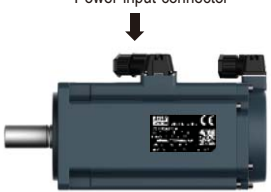
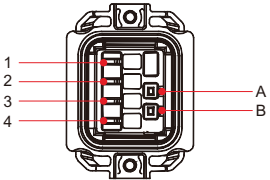
General specifications

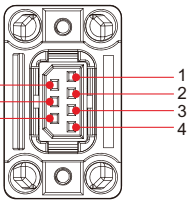
Cable Type	Terminal Layout (Cable Side)	Pin No.	Usage
 Power input connector		1	Phase V
		2	Phase U
		3	Phase W
		4	Grounding cable
		A	Brake (polarity insensi-tive)
		B	Brake (polarity insensi-tive)
 Encoder connector		1	DATA+
		2	DATA-
		3	BAT+
		4	BAT-
		5	+5V
		6	0V
		7	Enclosure

Mechanism Dimension

- 200W/400W

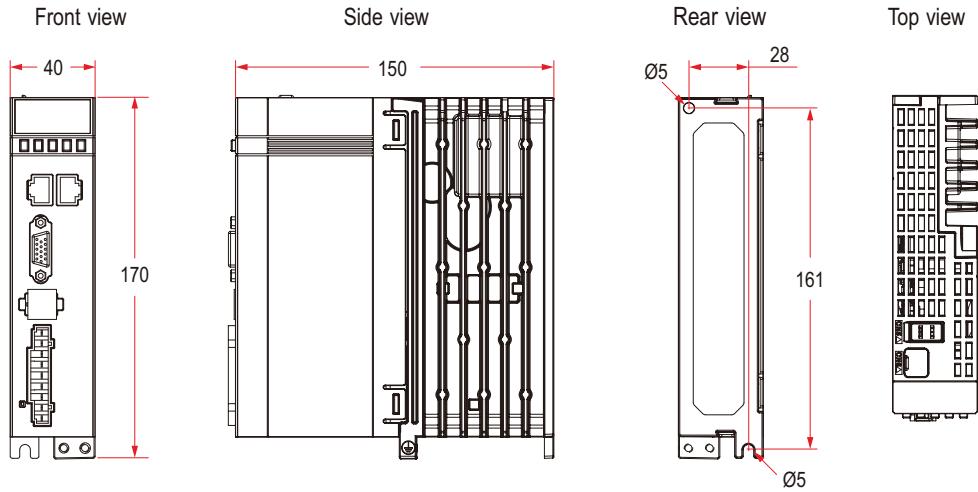

- 750W

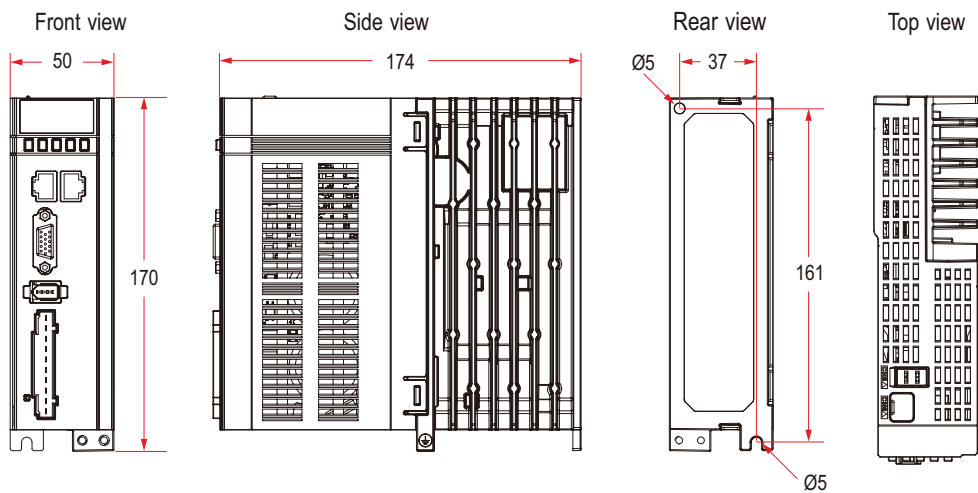

Mechanism Dimension

● 100W(40 frame)

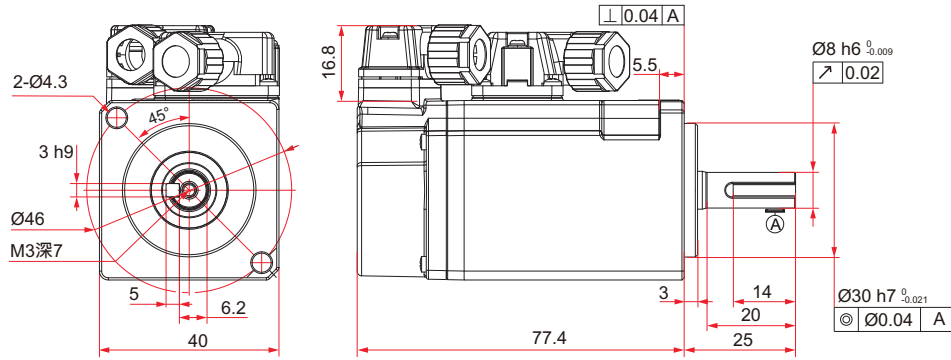

● 200W(60 frame)

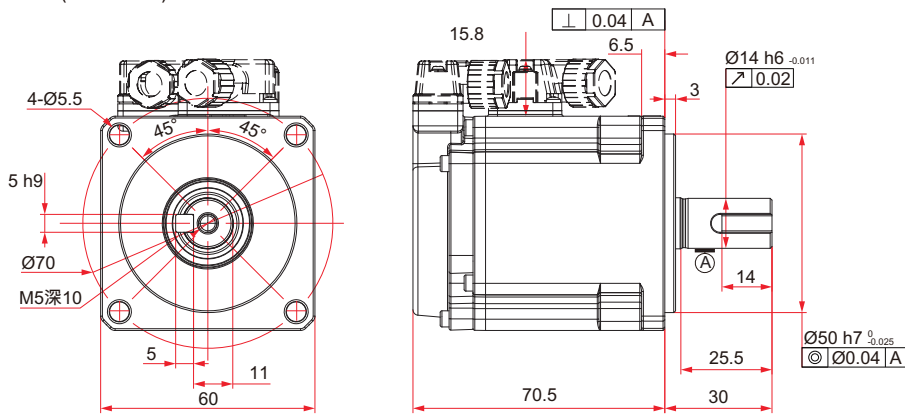

● 400W(60 frame)

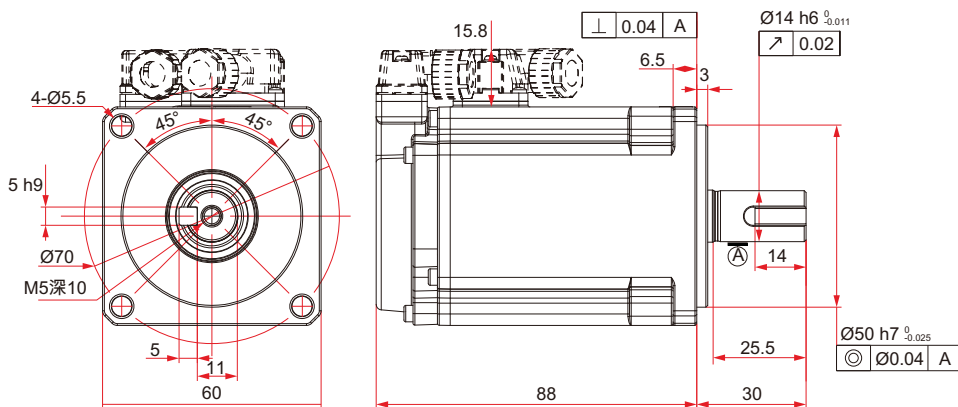

● 750W(80 frame)

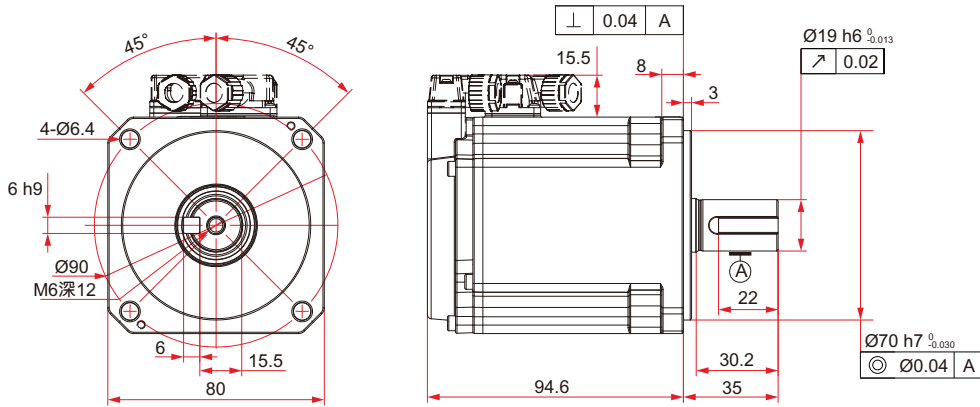

Product Selection

Driver & Motor Configuration Relationship

Driver Model	Motor model	Motor adaptation accessories		Brake Type
		Power cable model	Encoder cable model	
MD-730NS-020	MD-KS26N3C01	①	③	without brake
	MD-KS26C3C01	②		with brake
	MD-KS26S3C02	①		without brake
	MD-KS26E3C02	②		with brake
MD-730NS-040	MD-KS26S3C04	①	③	without brake
	MD-KS26E3C04	②		with brake
MD-730NS-075	MD-KS26S3C08	①	③	without brake
	MD-KS26E3C08	②		with brake

Cable Information (to be ordered separately)

Name	Model	Length	Exterior drawing	number
Power Line	MD-PWCR0-3/5/10	3/5/10m		①
Power Line	MD-PWCB0-3/5/10	3/5/10m		②
Encoder line	MD-ENCC2-3/5/10	3/5/10m		③
Servo drive 100 Gigabit pass Signal network cable	MD-NET-0.3/3	0.3/3m		
DB15 Terminal fittings	MD-DB15	---	<p>Welded surfaces</p>	
DB44 Terminal fittings	MD-DB44	---	<p>Welded surfaces</p>	

Note: If you have other model needs, please contact MEAN WELL dealers.